

20'

JUSTICE

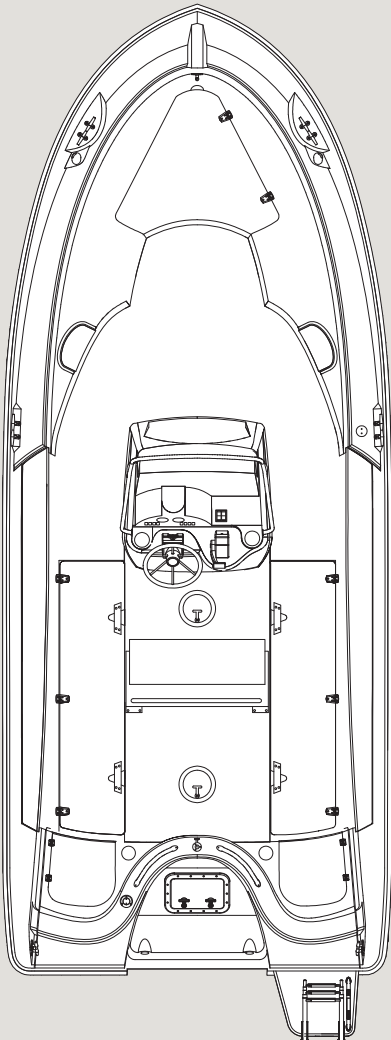

The deep-V hull of the Justice series affords smooth rides in rough conditions. Notable standard features of the 20' Justice include a dedicated bow anchor locker and a large fiberglass console with room to flush mount multiple electronics displays. Shown with options.

SPECIFICATIONS

	<i>US</i>	<i>METRIC</i>
• LOA	20' 6"	6.24 m
• Beam	8' 4"	2.54 m
• Draft	15"	.38 m
• Weight	2700 lbs	1224 kg
• Max Weight	3300 lbs	1496 kg
• Swamped Capacity	5500 lbs	2494 kg
• Person Capacity	10	–
• Max Horsepower	250 hp	186 kW
• Min Horsepower	135 hp	100 kW
• Max Engine Weight	700 lbs	317 kg
• Transom Height	25"	.63 m
• Fuel Capacity	95 gal	359 L

STANDARD FEATURES

- Unsinkable heavy-duty hull
- Self-bailing cockpit
- Bow and stern eyes
- 8" stainless steel cleats (2 bow, 2 spring line, 2 stern with hawse pipes)
- Heavy-duty rub rail
- Stainless steel swim ladder
- Stainless steel motorwell rails
- Stainless steel cockpit toe rails
- Acrylic windshield
- Drink holders (2)
- Courtesy lights (2)
- Compass
- Stainless steel grab rails
- Helm and companion footrests
- Cast stainless steel steering wheel with knob
- Electrical switch panel with circuit breaker
- Electronics mounting surface
- Port and starboard aft quarter seats
- Bow seating area
- Bow anchor locker with drain
- Console storage with stainless steel latch
- Storage under aft quarter seat
- 95-gallon fuel tank
- Automatic bilge pump
- Navigation lights
- Teleflex hydraulic tilt steering
- Electric horn
- Transducer Mount Area

This is only a partial list of standard features. To see the complete list, please contact your sales representative. Specifications are approximate and subject to variance.